







# MINI FLATIRON DESK



- PART LIST**  
A[1] TABLE TOP  
B[2] LEGS  
C[2] METAL POLE

NO.	Description		Q'TY
1.	Allen bolt		4Pcs
2.	LONG ALLEN BOLT		4Pcs
3.	Allen key		1Pc
4.	Nut A		4Pcs
5.	SHORT ALLEN BOLT		1Pc
6.	Nut B		1Pc

## ASSEMBLY INSTRUCTION

**Note:** Desk must be assembled by at least two persons. This instruction is written assuming two persons are assembling the desk.

### Step 1:

- Put the top (A) on a flat floor and turn the desk upside down. (Noted: the floor must be covered with protective material so that the item is not touching the floor directly).
- Position the leg (B) over the top (A) and align the leg onto given hole on the top (A) as shown in the sketch.
- Insert the Allen bolt (4) and tighten it using the Allen key (3).
- Repeat the procedure with the other leg.

### Step 2:

- Position the metal pole (C) and inset it to the clamp on the sidebeam of the leg (B).
- Insert the long Allen bolt (2), nut A (4) and tighten the bolt using allen key (3) as the shown in the sketch.
- Connect the two metal poles with the short Allen bolt (5) and nut B (6), tighten the bolt using allen key (3) as the shown in the sketch.

Turn the desk up to complete.

## STEP 1:

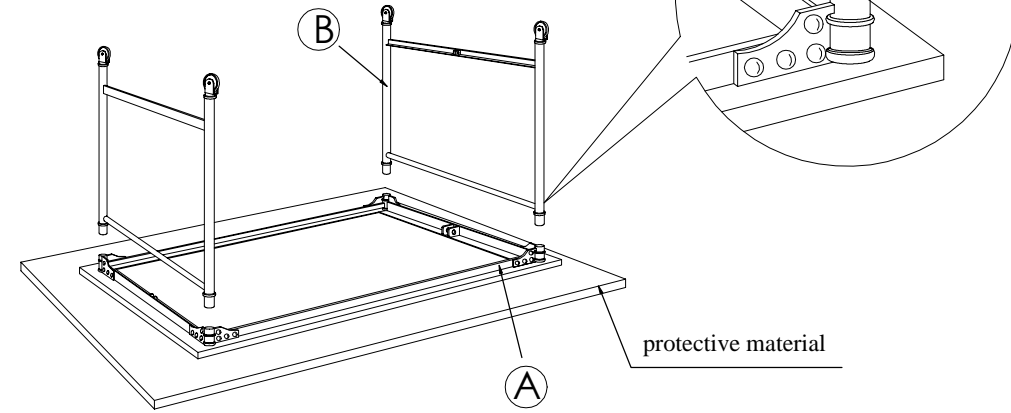

## STEP 2:

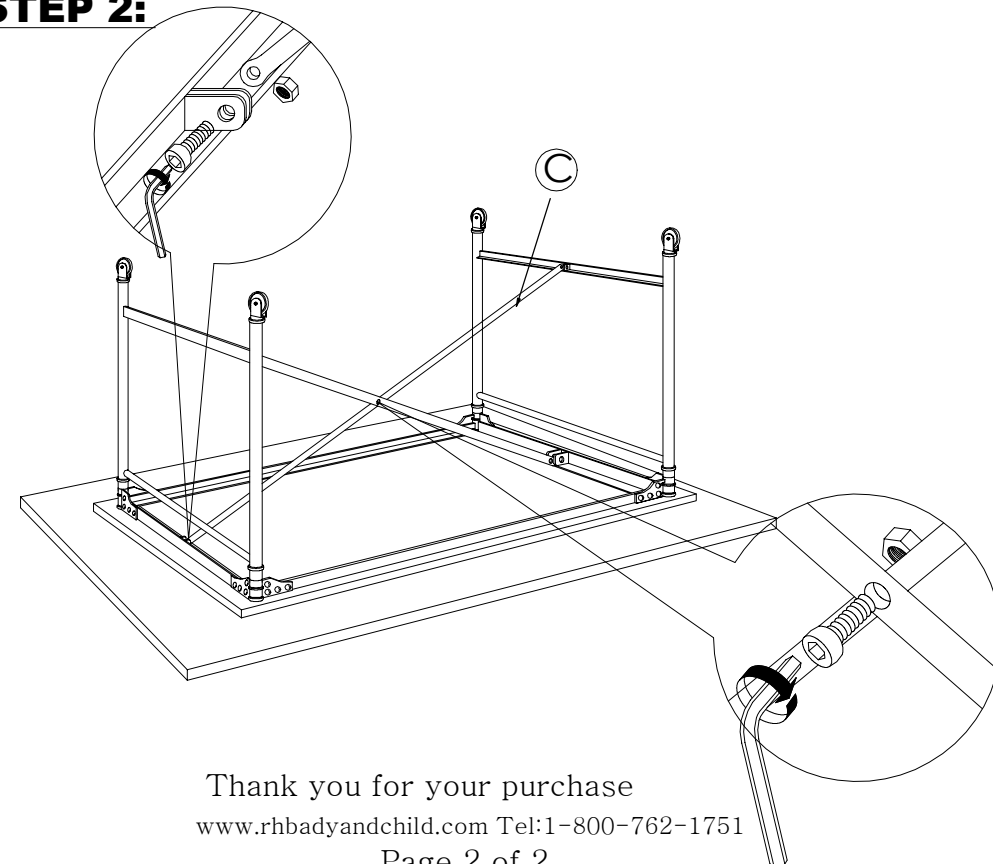

Thank you for your purchase

www.rhbabyandchild.com Tel:1-800-762-1751