

Vintage Field Desk Assembly Instructions

CONTENTS

- A Desk body – already assembled
- B Desk top with fold-away support frame
- C Stool with fold-away support frames

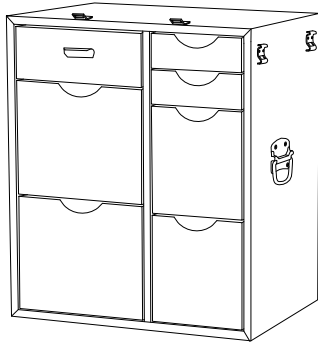

A

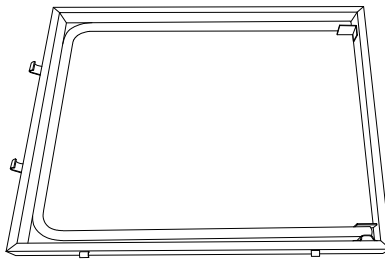

B

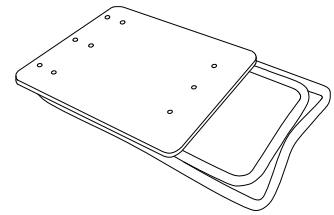

C

ASSEMBLY INSTRUCTIONS

1. Carefully unpack the desk and remove from packaging.
2. Lay down the complete trunk (which contain three parts A, B and C above) on a protected surface, front side facing up.
3. Unfasten the two latches on both sides of the top panel (Fig.1).
4. This panel becomes the desktop with fold-away leg (B).
5. Stand the desk body (A) upright and hook the desktop onto the side panel (Fig. 2).
6. From underneath the desktop, unclip the fold-away support and place in an upright position (Fig. 3).

NOTE: For your convenience the desktop can be installed on either the left or the right side of the desk (Fig.4).

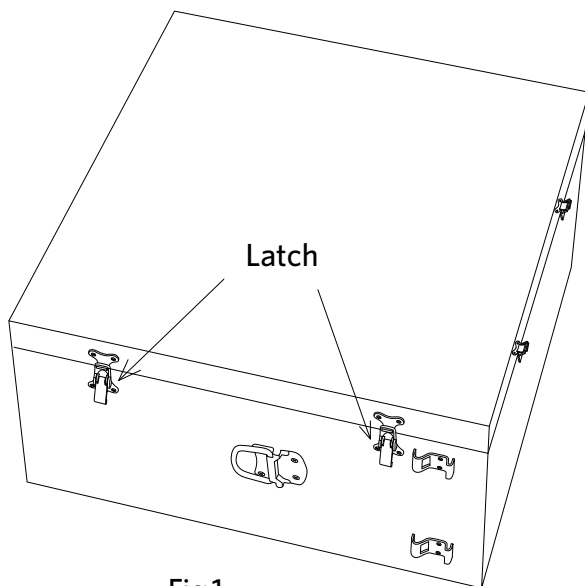

Fig.1

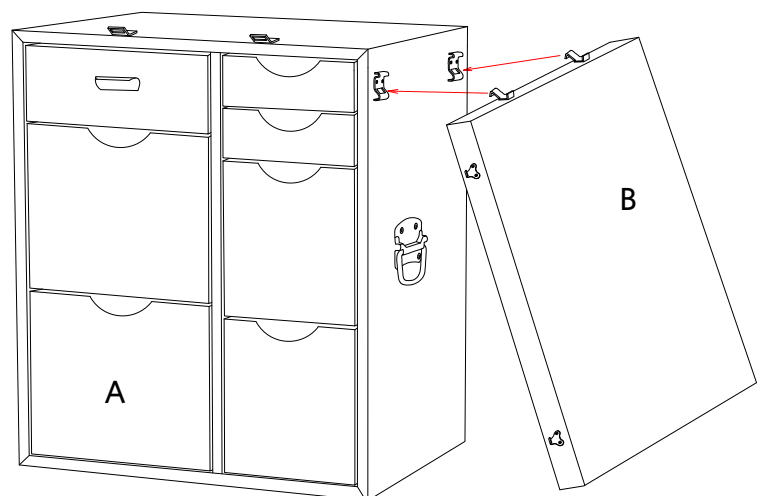

Fig.2

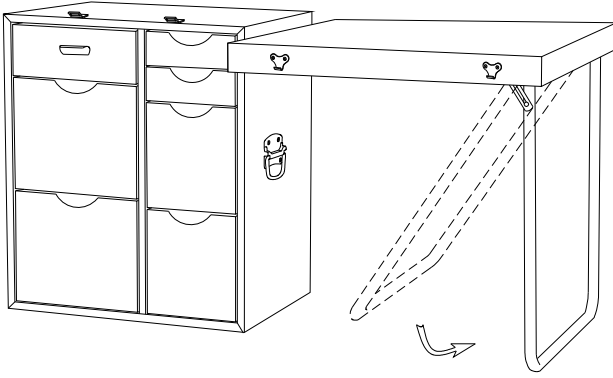

Fig.3

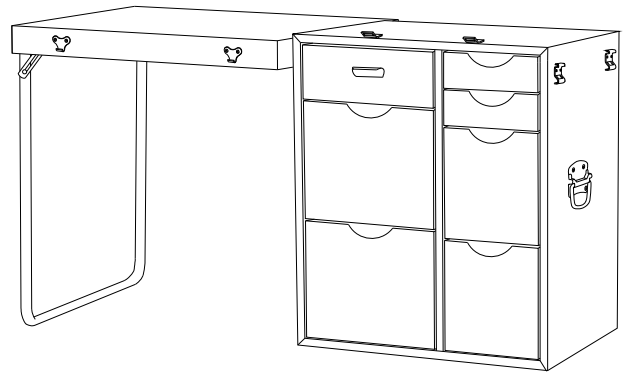

Fig.4

7. The stool (C) is folded away when the trunk is opened.

- 1). Lift the top and rotate the fold-away support frame.
- 2). Engage with clips on underside of stool top (Fig. 5).

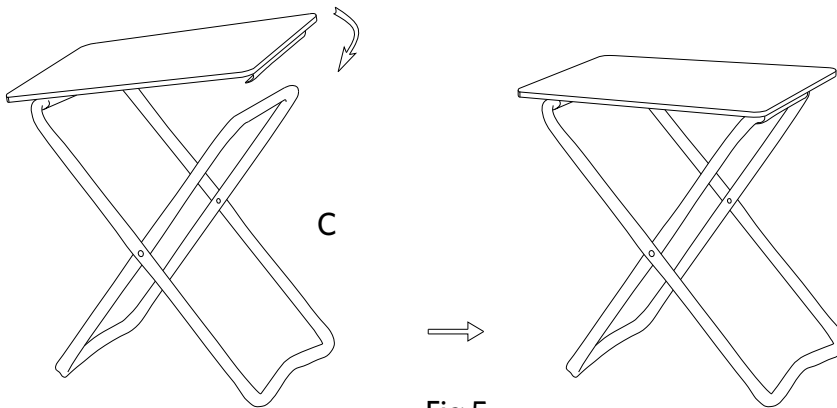

Fig.5

6. The Vintage Field Desk assembly is complete (Fig.6).

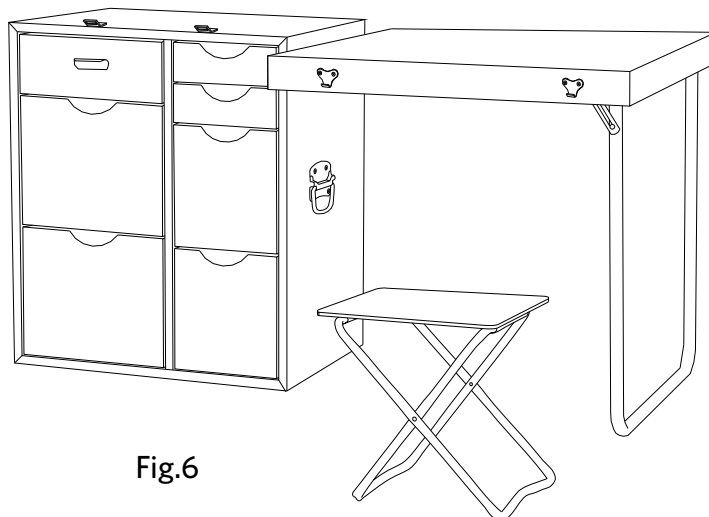

Fig.6

CARE INSTRUCTIONS: Wipe clean with a damp cloth.

Thank you for your purchase.

www.rhbabyandchild.com