

# RH BABY & CHILD

## COLE FRAMED BED QUEEN – ASSEMBLY INSTRUCTIONS

Model No: 355 - 125

### PARTS INCLUDED:

- A [2] SIDE FRAME
- B [1] SLAT ROLL
- C [2] SIDE RAIL
- D [1] CENTER STRETCHER
- E [2] SIDE STRETCHER
- F [5] SUPPORT LEG





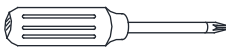





### TOOLS NEEDED:

Phillips-head screwdriver (not included)

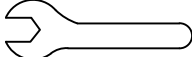
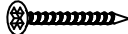

### NOTE:

- Bed must be assembled by at least two people.
- Please read instructions carefully before assembling bed.
- Use the parts and fittings list to identify each component.
- Keep all packing materials until assembly is complete to avoid loss of smaller parts.
- Do not completely tighten all bolts until all steps are finished.

NO.	ITEM	DESCRIPTION	QTY.
1		Long Bolt 5/16" x 2-1/4"	2 pcs.
2		Spring Washer 5/16"	2 pcs.
3		Flat Washer 5/16"	2 pcs.
4		Allen Key 4mm	1 pc.
5		Threaded Rod 5/16" x 2-3/4"	4 pcs.
6		Screws 8 x 30mm	4 pcs.
7		Hex Nut 5/16" x 12mm	4 pcs.
8		Curved Slotted Washer 35 x 16 x 12 x 3 mm	4 pcs.
9		Multi Wrench 12mm	1 pc.
10		Extra Long Screws 7 x 35mm	6 pcs.
11		Extra Metal Bracket	2 pcs.

### ASSEMBLY INSTRUCTIONS:

#### STEP 1:

Insert the Threaded Rods (5) into the posts of the Side Frames (A).

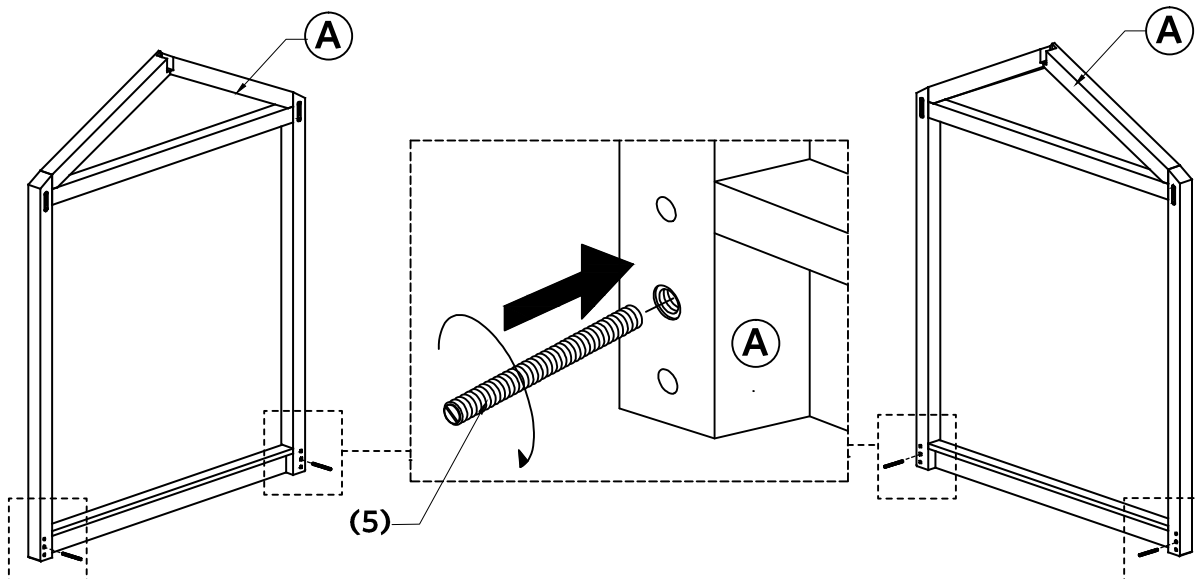

# RH BABY & CHILD

## COLE FRAMED BED QUEEN – ASSEMBLY INSTRUCTIONS Model No: 355 - 125

### STEP 2:

- Slide the Side Rails (C) onto the Side Frames (A).
- Insert Curved Slotted Washer (8), and Hex Nut (7), then tighten with Multi Wrench (9).
- **Do not tighten bolts completely at this time in order to leave room for installation of Stretcher (E) hooks in the next step.**

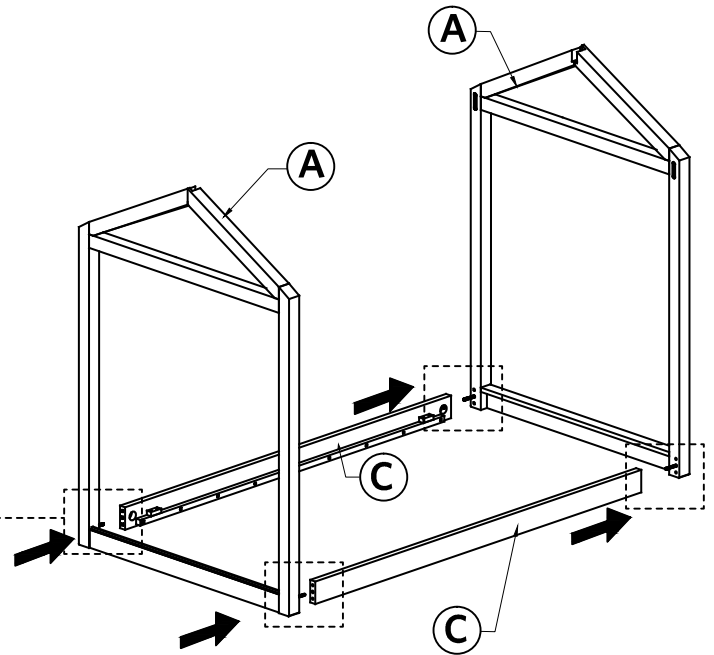
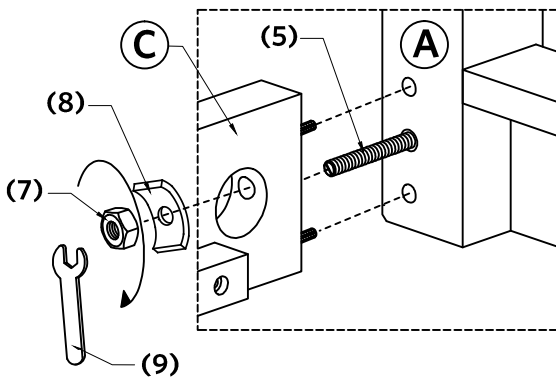

### STEP 3:

2 people are needed to assemble Stretcher (E). At the same time, insert the 2 stretchers into the metal brackets on the post of Side Frame (A). Slightly push the stretchers down to be flush with posts. **DO NOT MOVE THE BED AT THIS STAGE.**

Please always have 2 people move the bed at the same time if it needs to be moved.

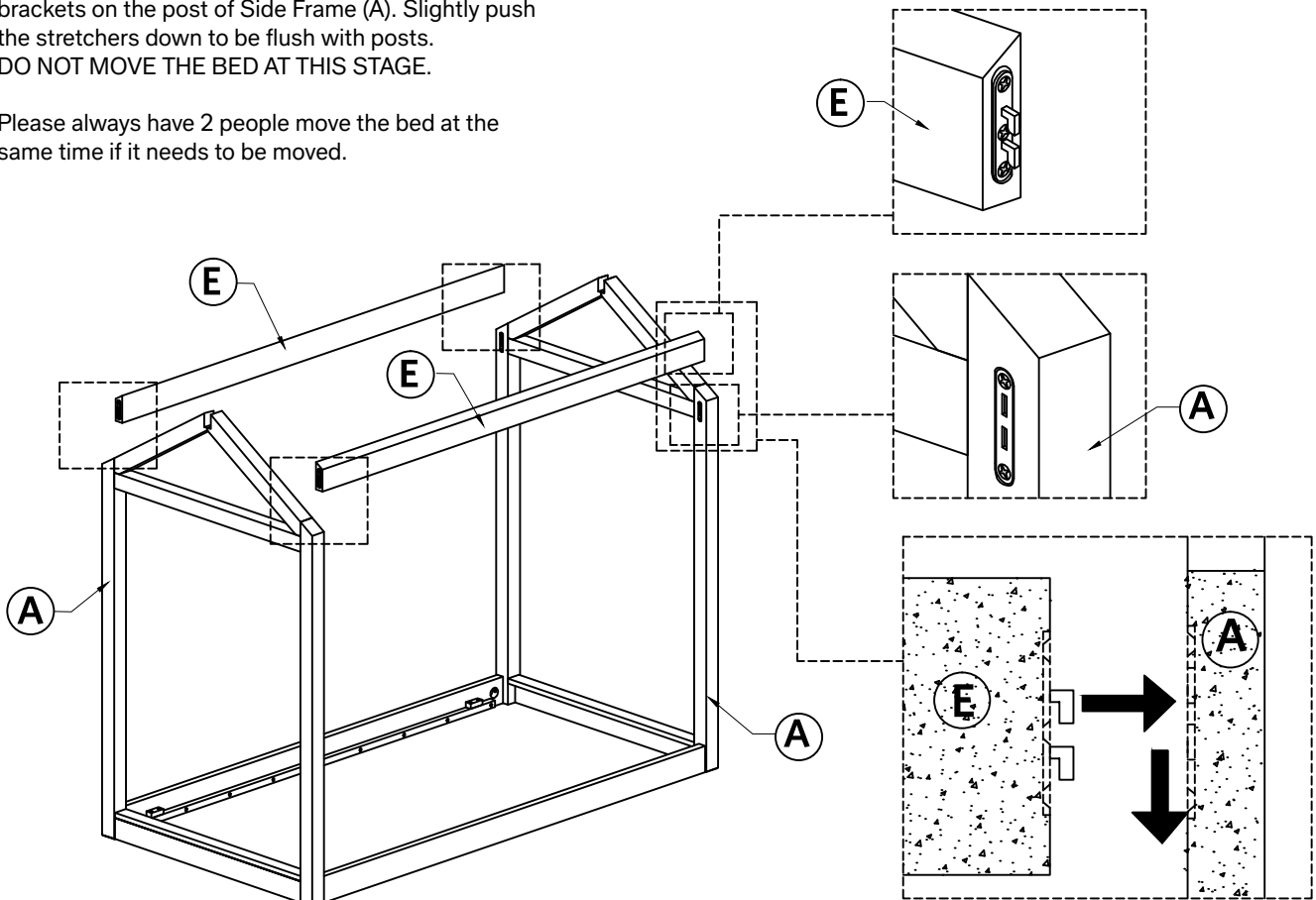

# RH BABY & CHILD

## COLE FRAMED BED QUEEN – ASSEMBLY INSTRUCTIONS Model No: 355 - 125

### INSTRUCTIONS TO REPLACE METAL BRACKETS IF NEEDED:

If the metal bracket malfunctions or becomes damaged, please replace it with an extra metal bracket.

Unscrew the wooden screws with a Phillips-head screwdriver, then remove the damaged Metal Bracket.

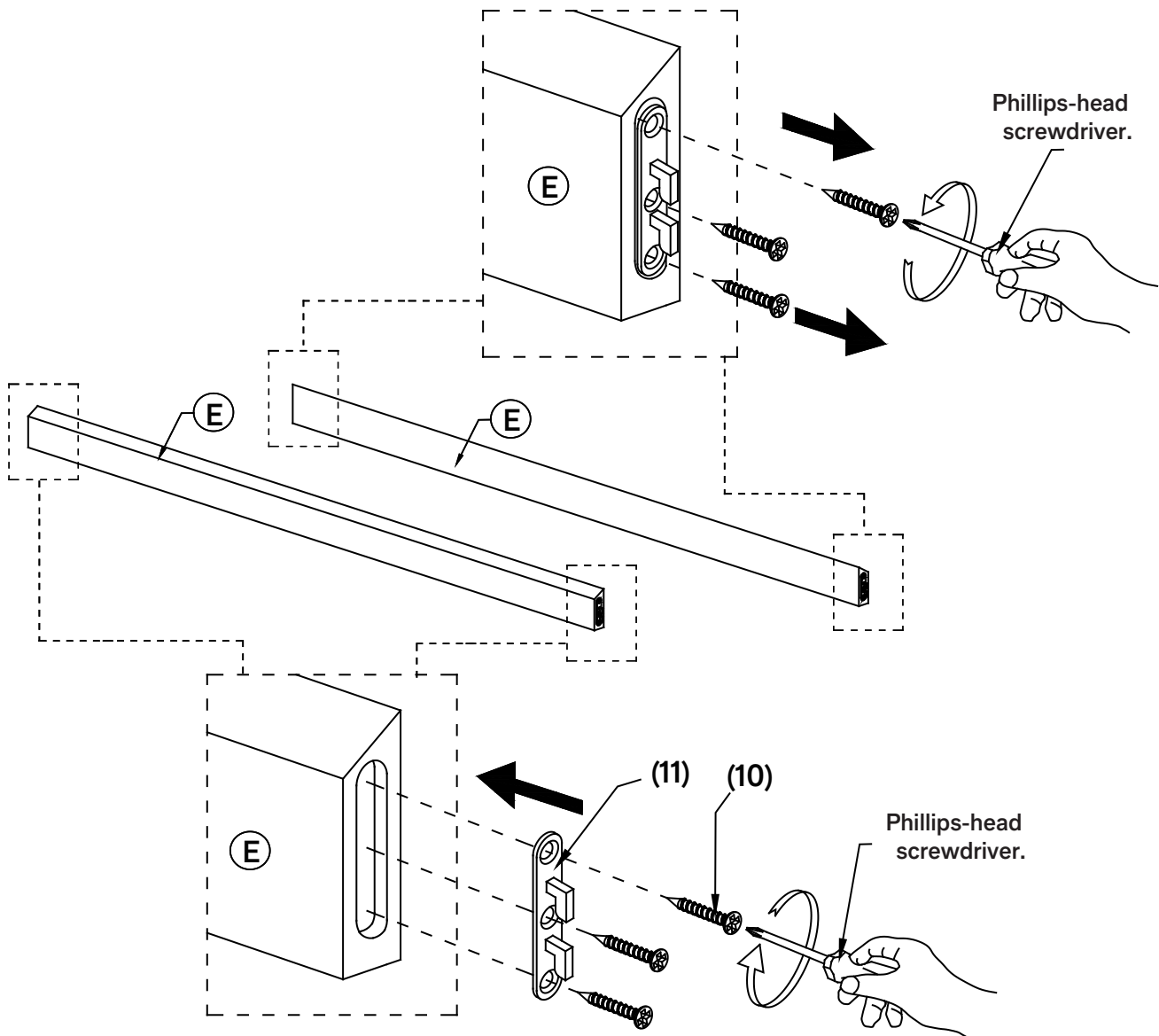

Install the new Metal Bracket (11) to the top of Side Stretcher (E) using new Wood Screws (10). Tighten the screws with a Phillips-head screwdriver.

# RHBABY&CHILD

## COLE FRAMED BED QUEEN – ASSEMBLY INSTRUCTIONS Model No: 355 - 125

### STEP 4:

Insert the Center Stretcher (D) onto the top of Side Frames (A) by using Long Bolts (1), Spring Washers (2), Flat Washers (3), and use Allen Key (4) to tighten.

**Tighten all side rail bolts.**

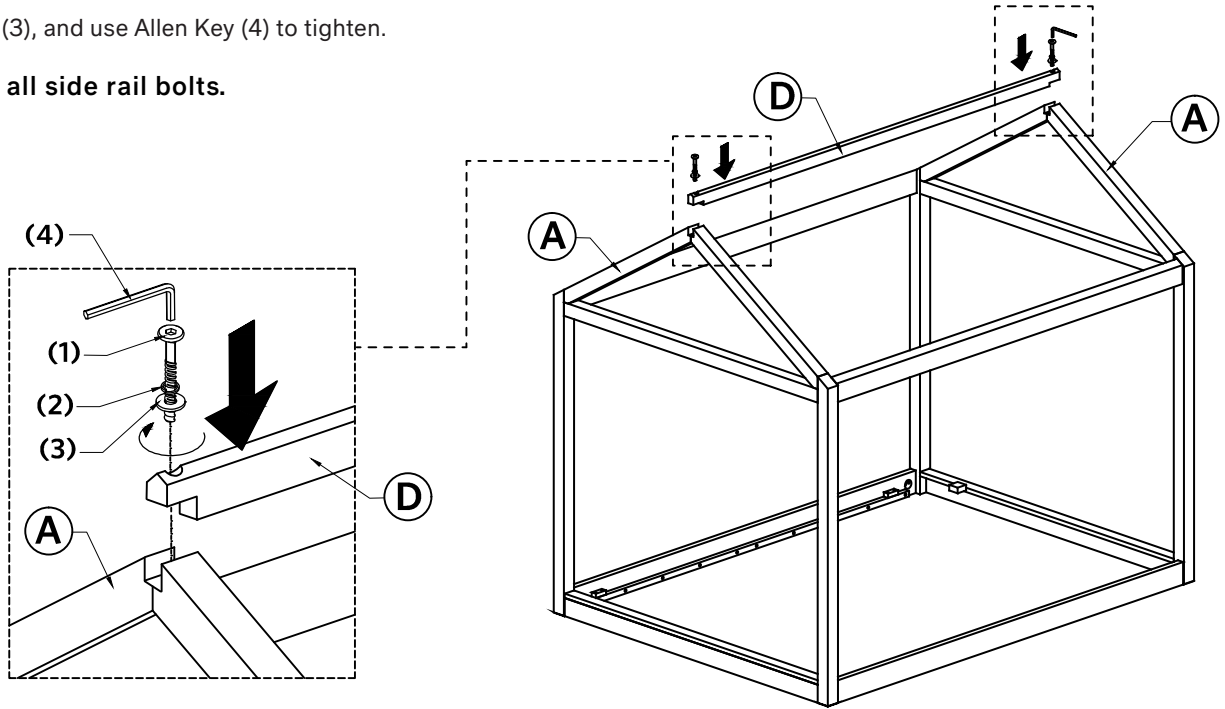

### STEP 5:

Tighten the Support Legs (F) to the bottom of Slat Roll (B).

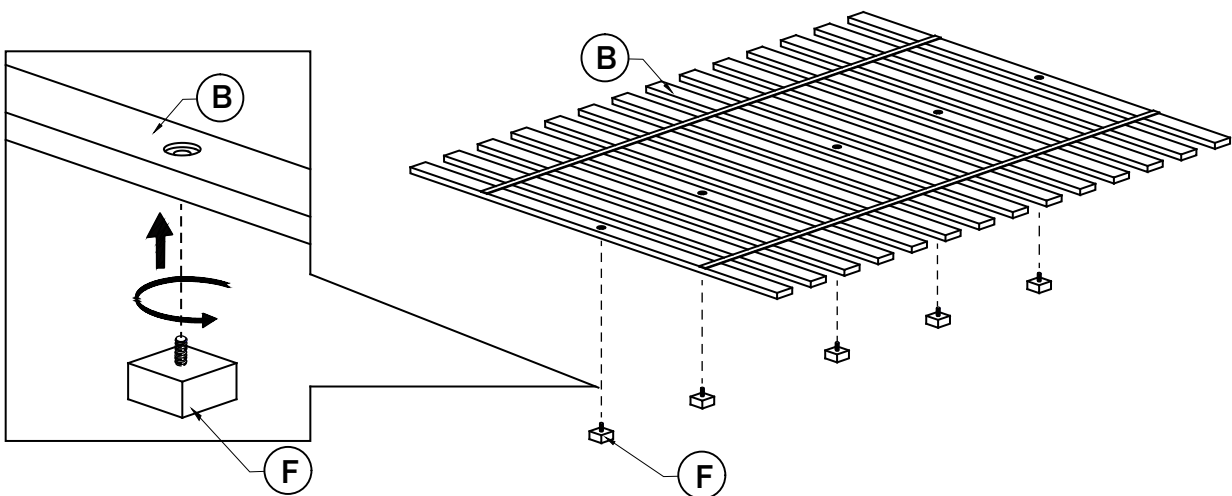

# RHBABY&CHILD

## COLE FRAMED BED QUEEN – ASSEMBLY INSTRUCTIONS Model No: 355 - 125

### STEP 6:

Lay the Slat Roll (B) between the Side Rails (C) and attach using Screws (6) with Phillips-head screwdriver (not provided).

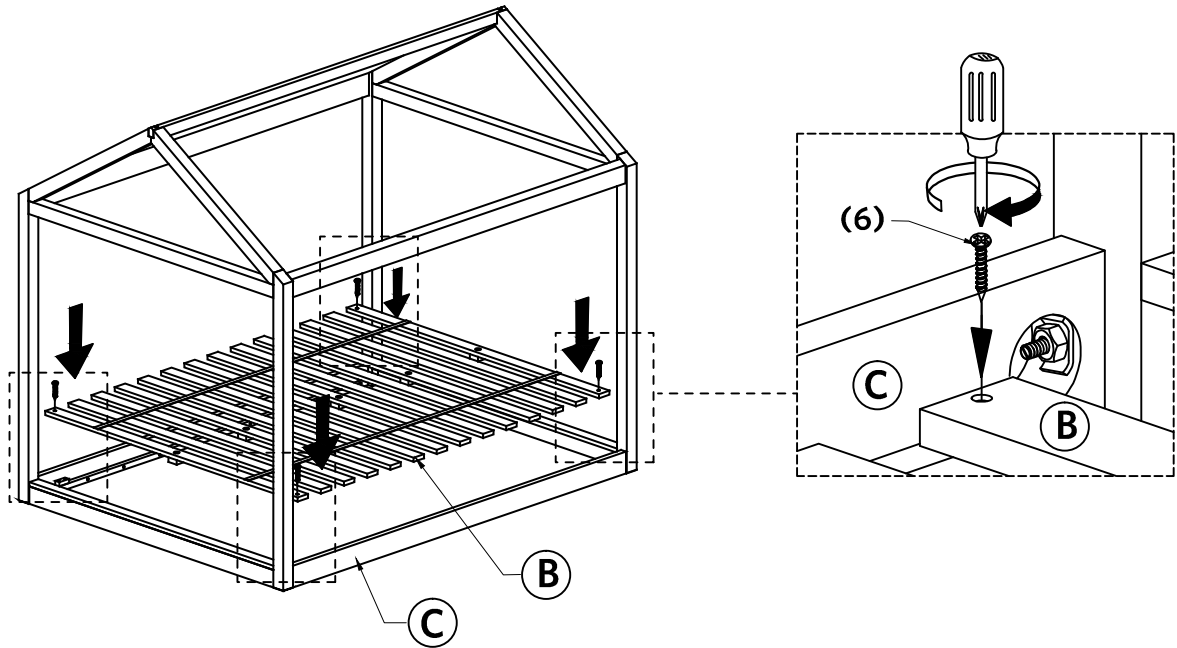

### STEP 7:

If needed, adjust the levelers underneath the posts of the Side Frame (A).

**Note: Maximum loading 800lbs**

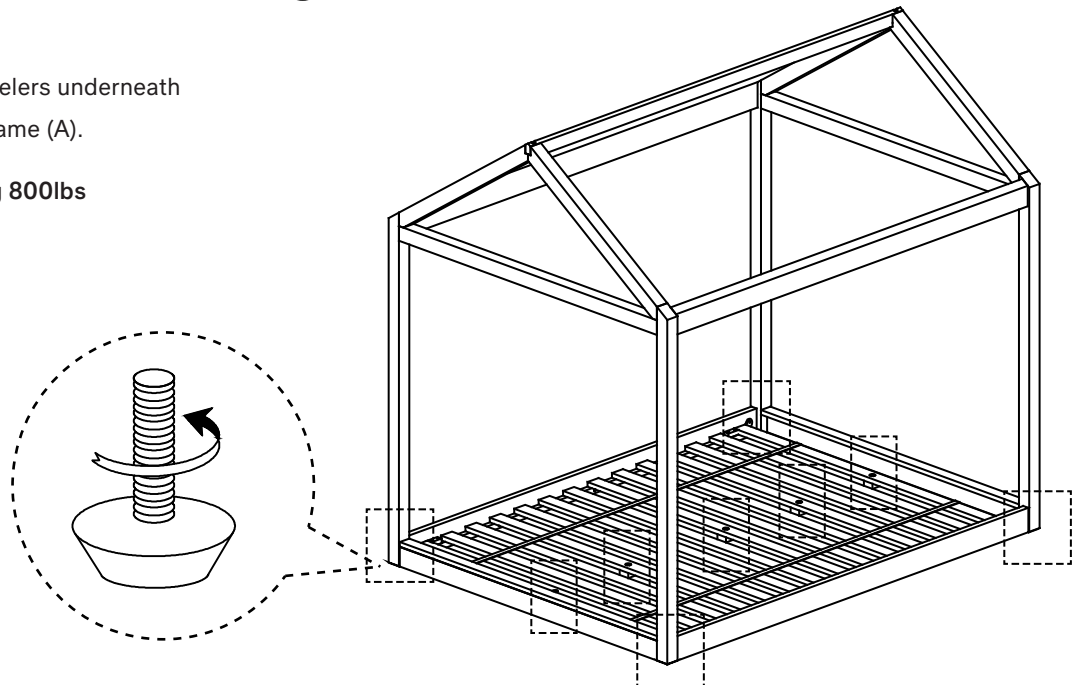

### CARE INSTRUCTIONS:

1. DUST OFTEN USING A CLEAN, SOFT, DRY LINT- FREE CLOTH.
2. BLOT SPILLS IMMEDIATELY AND WIPE WITH A CLEAN, DAMP CLOTH.
3. DO NOT USE CHEMICAL CLEANERS, ABRASIVES OR FURNITURE POLISH ON THE LACQUERED FINISH.