

RH BABY & CHILD

COLE FRAMED BED TWIN & FULL – ASSEMBLY INSTRUCTIONS

Model No: 355 - 95 & 96

PARTS INCLUDED:

- A [2] SIDE FRAME
- B [1] SLAT ROLL
- C [2] SIDE RAIL
- D [1] CENTER STRETCHER
- E [2] SIDE STRETCHER

TOOLS NEEDED:

Phillips-head screwdriver (not included)

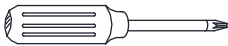









NOTE:

- Bed must be assembled by at least two people.
- Please read instructions carefully before assembling bed.
- Use the parts and fittings list to identify each component.
- Keep all packing materials until assembly is complete to avoid loss of smaller parts.
- Do not completely tighten all bolts until all steps are finished.

ASSEMBLY INSTRUCTIONS:

STEP 1:

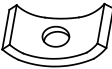
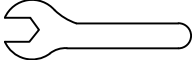
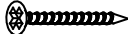
Insert the Threaded Rods (5) into the posts of the Side Frames (A).

NO.	ITEM	DESCRIPTION	QTY.
1		Long Bolt 5/16" x 2-1/4"	2 pcs.
2		Spring Washer 5/16"	2 pcs.
3		Flat Washer 5/16"	2 pcs.
4		Allen Key 4mm	1 pc.
5		Threaded Rod 5/16" x 2-3/4"	4 pcs.
6		Screws 8 x 30mm	4 pcs.
7		Hex Nut 5/16" x 12mm	4 pcs.
8		Curved Slotted Washer 35 x 16 x 12 x 3 mm	4 pcs.
9		Multi Wrench 12mm	1 pc.
10		Extra Long Screws 7 x 35mm	6 pcs.
11		Extra Metal Bracket	2 pcs.

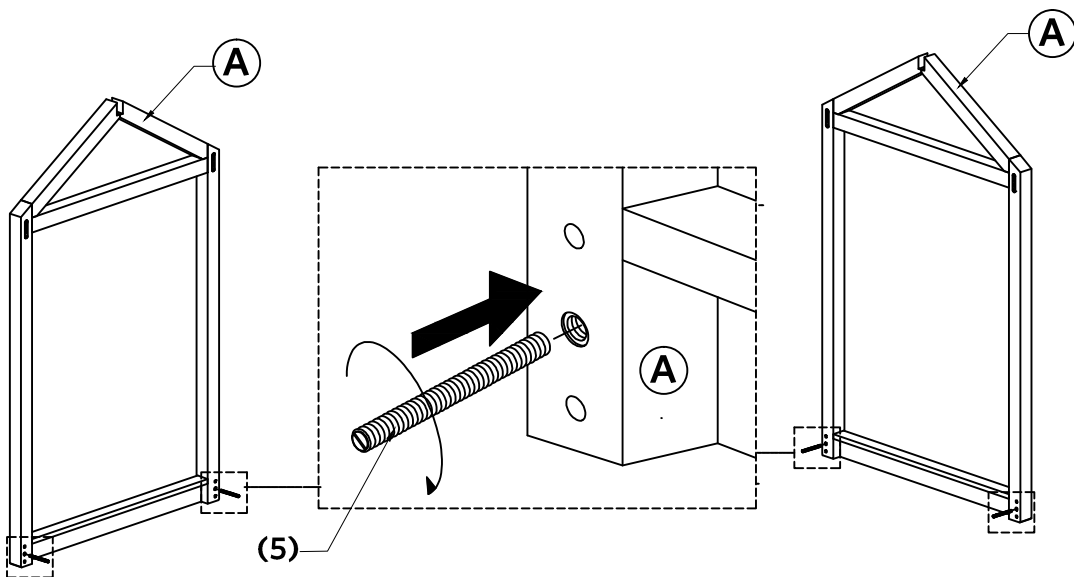

RH BABY & CHILD

COLE FRAMED BED TWIN & FULL – ASSEMBLY INSTRUCTIONS

Model No: 355 - 95 & 96

STEP 2:

- Slide the Side Rails (C) onto the Side Frames (A).
- Insert Curved Slotted Washer (8), and Hex Nut (7), then tighten with Multi Wrench (9).
- **Do not tighten bolts completely at this time in order to leave room for installation of Stretcher (E) hooks in the next step.**

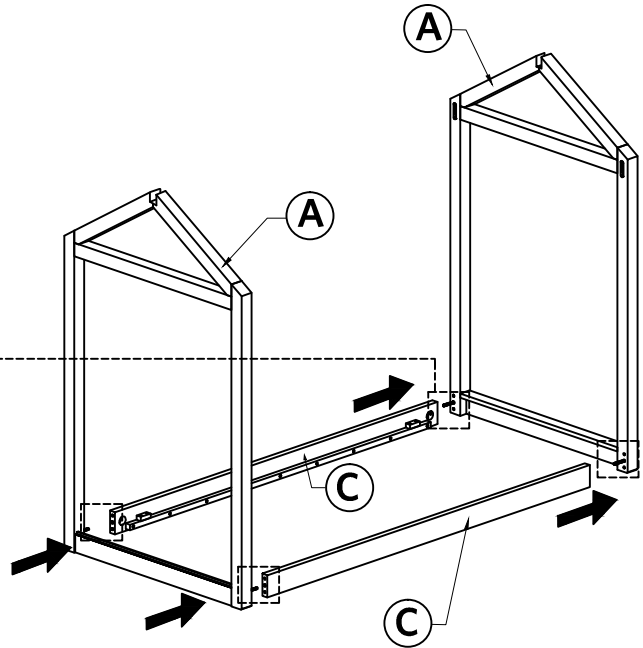
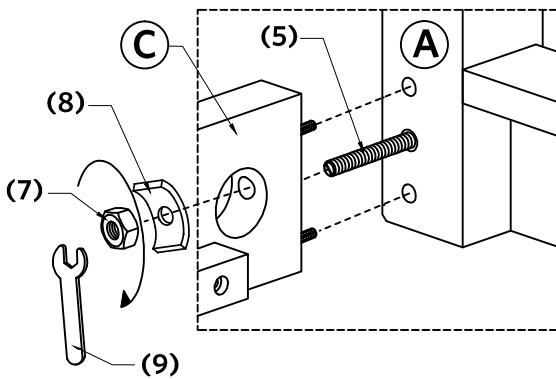

STEP 3:

2 people are needed to assemble Stretcher (E). At the same time, insert the 2 stretchers into the metal brackets on the post of Side Frame (A). Slightly push the stretchers down to be flush with posts. **DO NOT MOVE THE BED AT THIS STAGE.**

Please always have 2 people move the bed at the same time if it needs to be moved.

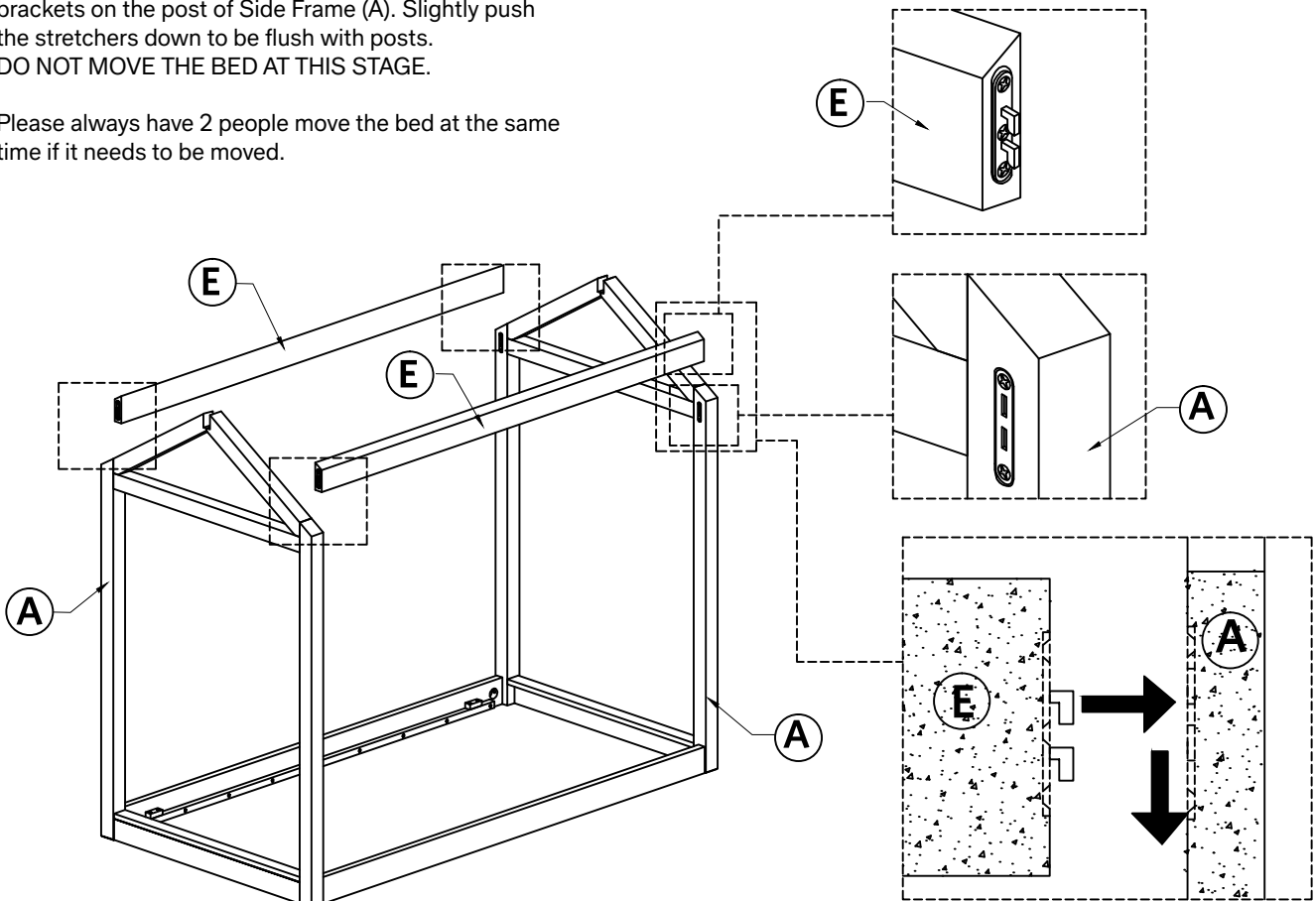

RH BABY & CHILD

COLE FRAMED BED TWIN & FULL – ASSEMBLY INSTRUCTIONS Model No: 355 - 95 & 96

INSTRUCTIONS TO REPLACE METAL BRACKETS IF NEEDED:

If the metal bracket malfunctions or becomes damaged, please replace it with an extra metal bracket.

Unscrew the wooden screws with a Phillips-head screwdriver, then remove the damaged Metal Bracket.

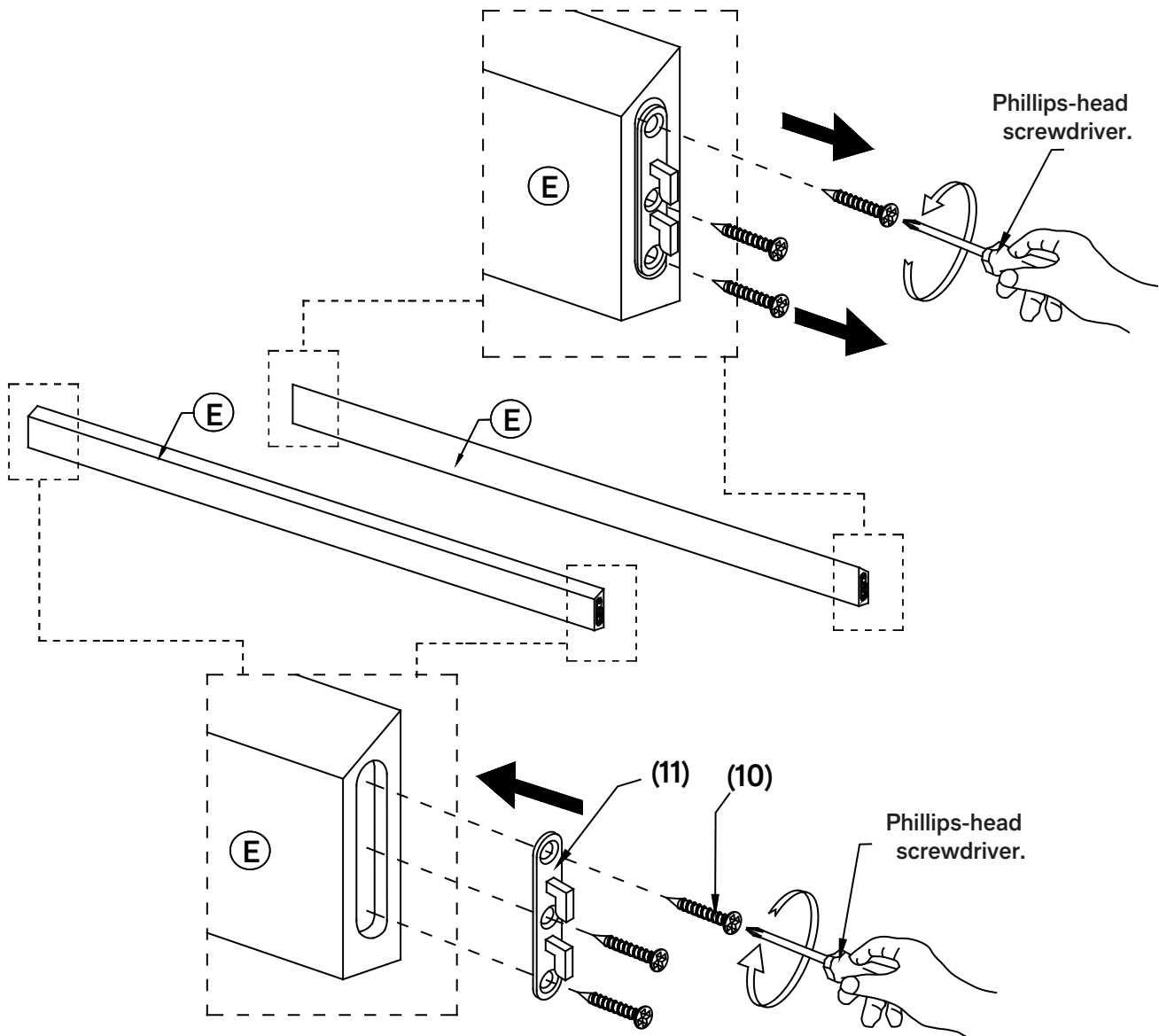

Install the new Metal Bracket (11) to the top of Side Stretcher (E) using new Wood Screws (10). Tighten the screws with a Phillips-head screwdriver.

RHBABY&CHILD

COLE FRAMED BED TWIN & FULL – ASSEMBLY INSTRUCTIONS

Model No: 355 - 95 & 96

STEP 4:

Insert the Center Stretcher (D) onto the top of Side Frames (A) by using Long Bolts (1), Spring Washers (2), Flat Washers (3), and use Allen Key (4) to tighten.

Tighten all side rail bolts.

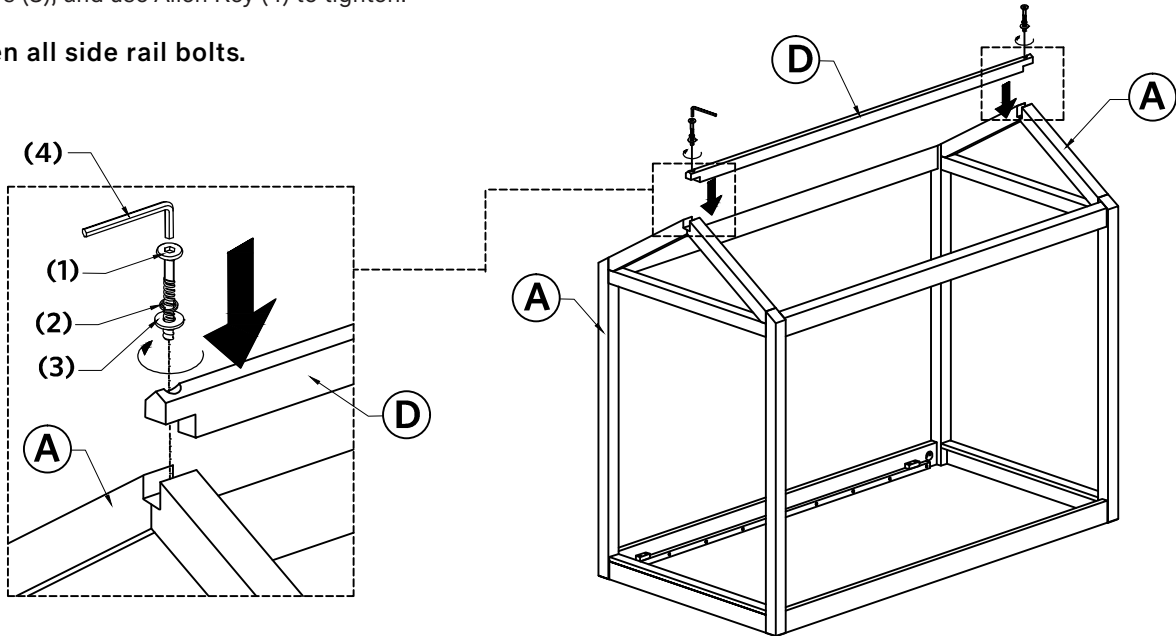

STEP 5:

Lay the Slat Roll (B) between the Side Rails (C) and attach using Screws (6) with Phillips-head screwdriver (not provided).

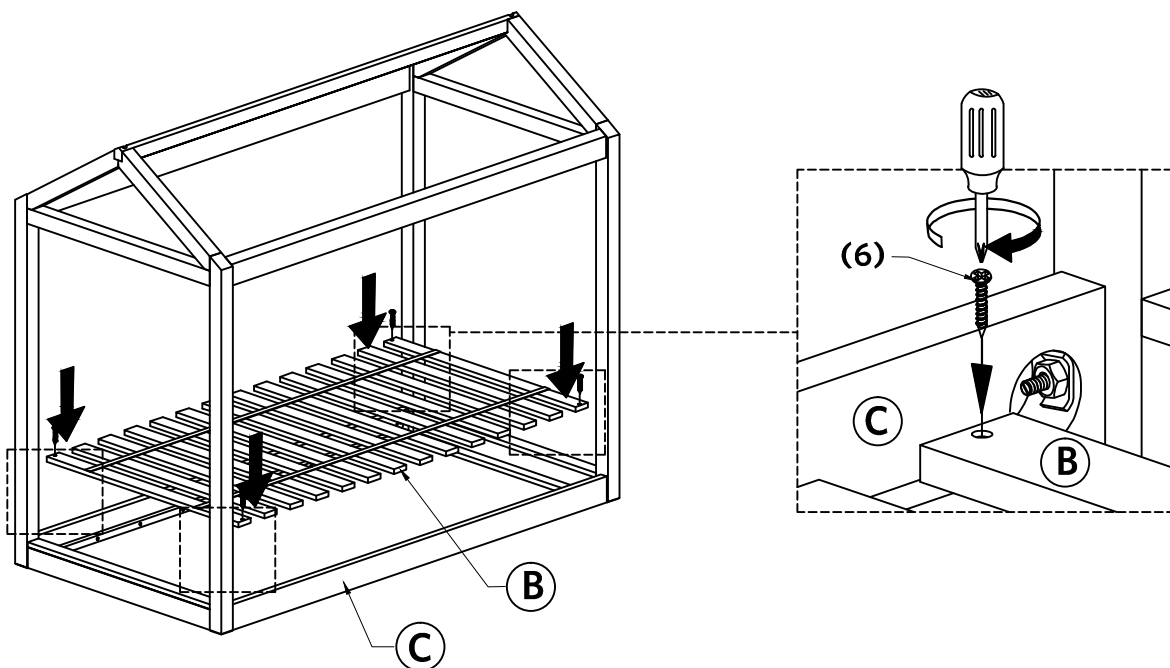

RH BABY & CHILD

COLE FRAMED BED TWIN & FULL – ASSEMBLY INSTRUCTIONS Model No: 355 - 95 & 96

STEP 6:

If needed, adjust the levelers underneath the posts of the Side Frame (A).

Note: Maximum loading

- Single/Twin 500 lbs.

- Full 800 lbs

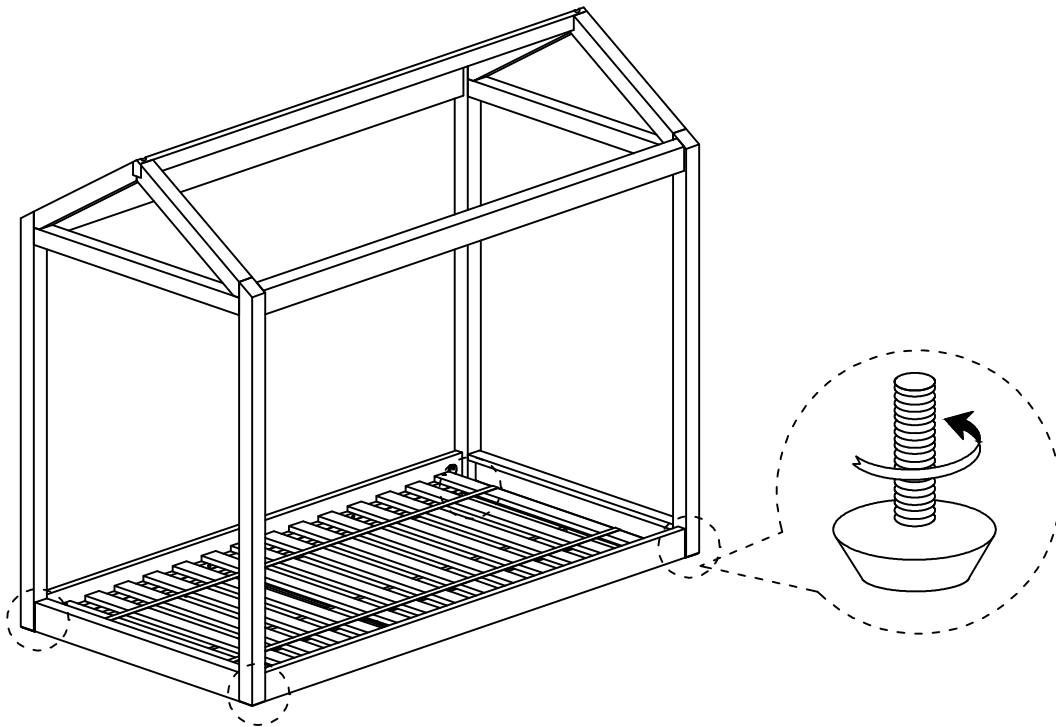

CARE INSTRUCTIONS:

1. DUST OFTEN USING A CLEAN, SOFT, DRY LINT-FREE CLOTH.
2. BLOT SPILLS IMMEDIATELY AND WIPE WITH A CLEAN, DAMP CLOTH.
3. DO NOT USE CHEMICAL CLEANERS, ABRASIVES OR FURNITURE POLISH ON THE LACQUERED FINISH.