

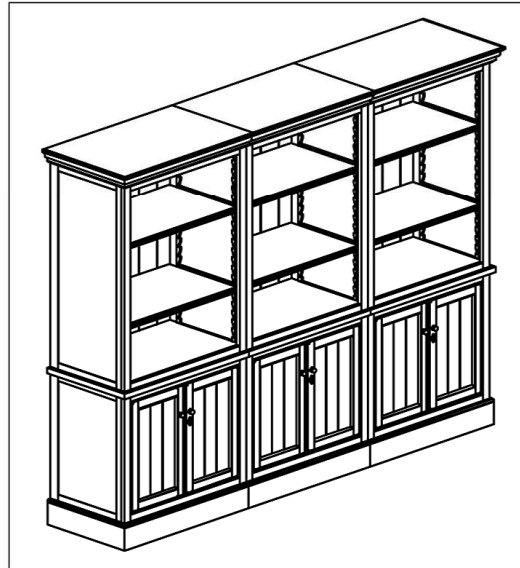



baby & child **HARPER STORAGE WALL**





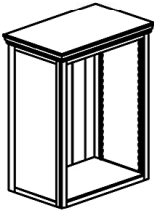
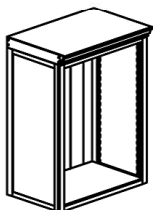
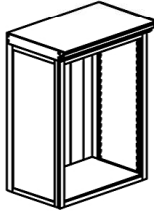
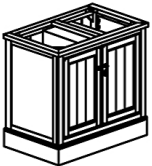



PRE - ASSEMBLY:

**Please read all instructions before beginning assembly.
For ease of assembly, two adults are recommended.
Save all packing materials until completed assembling.**

PARTS LIST :

			
(A) Left Hutch -1 pc	(B) Middle Hutch -1 pc	(C) Right Hutch- 1 pc	(D) Left Base - 1 pc
			
(E) Middle Base - 1 pc	(F) Right Base -1 pc	(G) Shelves - 9 pcs	(H) Shelf Holder -18 pcs

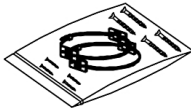
HARDWARE LIST :

			
(H-1) Allen Bolt 6 x 35 -16 pcs	(H-2) Flat Washer - 16 pcs	(H-3) Lock Washer - 16 pcs	(H-4) Screw 4 x 20 - 6 pcs
			
(H-5) Anti-Tip Kit - 2 pcs	(T-1) Allen Key - 1 pc	(T-2) Phillips Screw Driver - 1 pc (Not provided)	

Assembly Steps

Step 1:

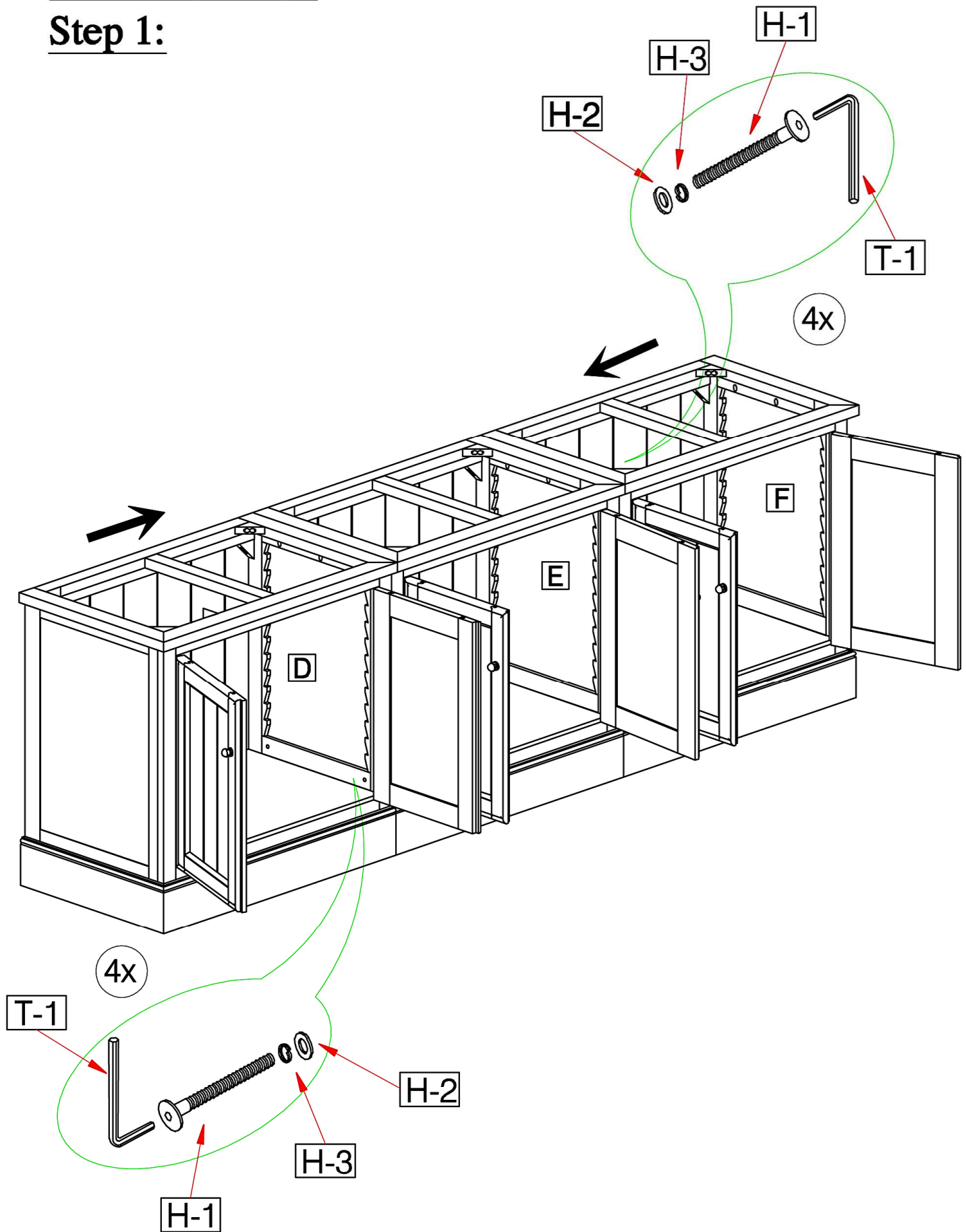

Position and secure Left Base (D), Right Base (F) to Middle Base (E) using Allen Bolt (H-1), Lock Washer (H-3) and Flat Washer (H-2). Tighten all Bolts using Allen Key (T-1).

Step 2:

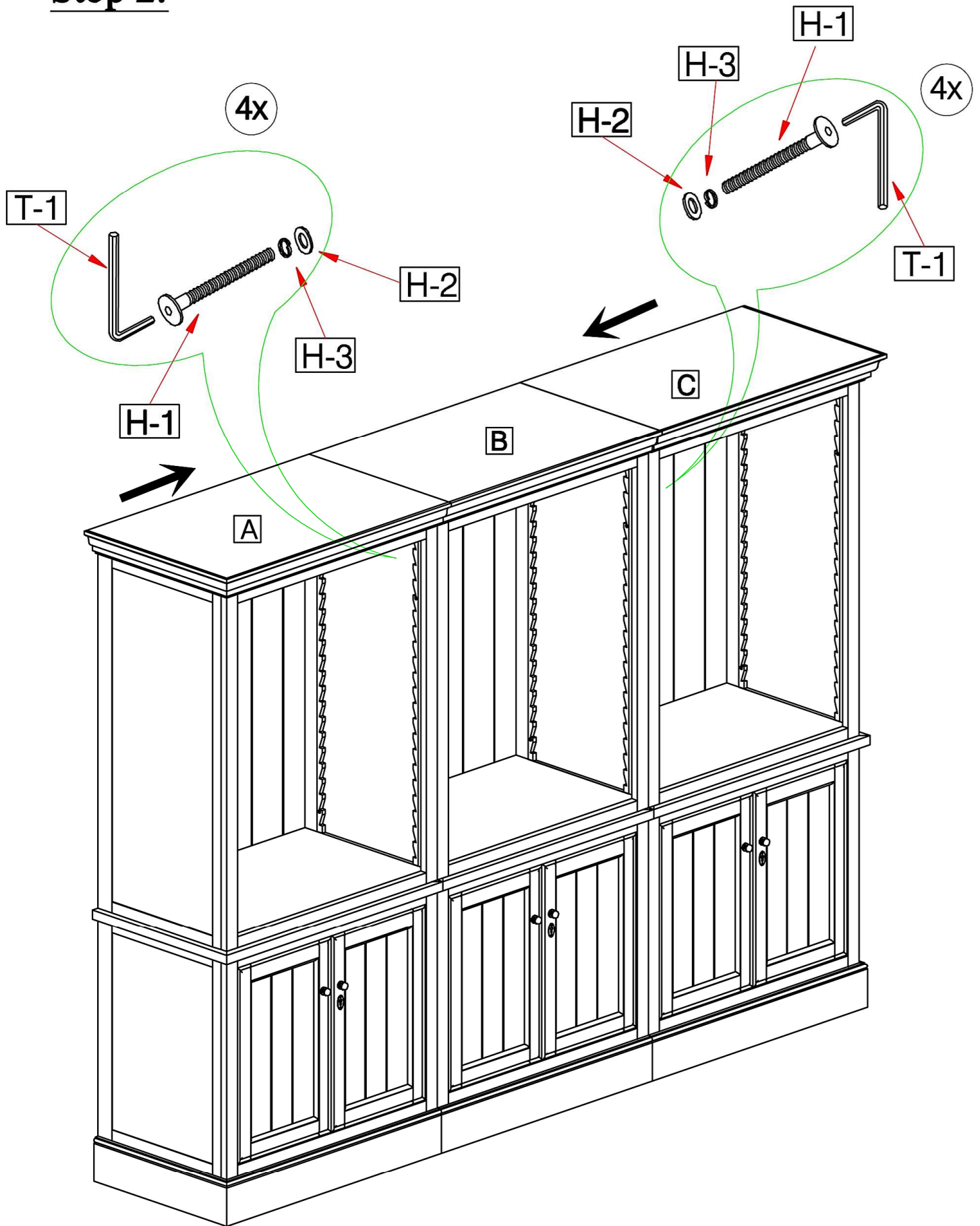

Place Hutches on the Base unit. Position and secure Left Hutch (A), Right Hutch (C) to Middle Hutch (B) using Allen Bolt (H-1), Lock Washer (H-3) and Flat Washer (H-2). Tighten all bolts using Allen Key (T-1).

Step 3:

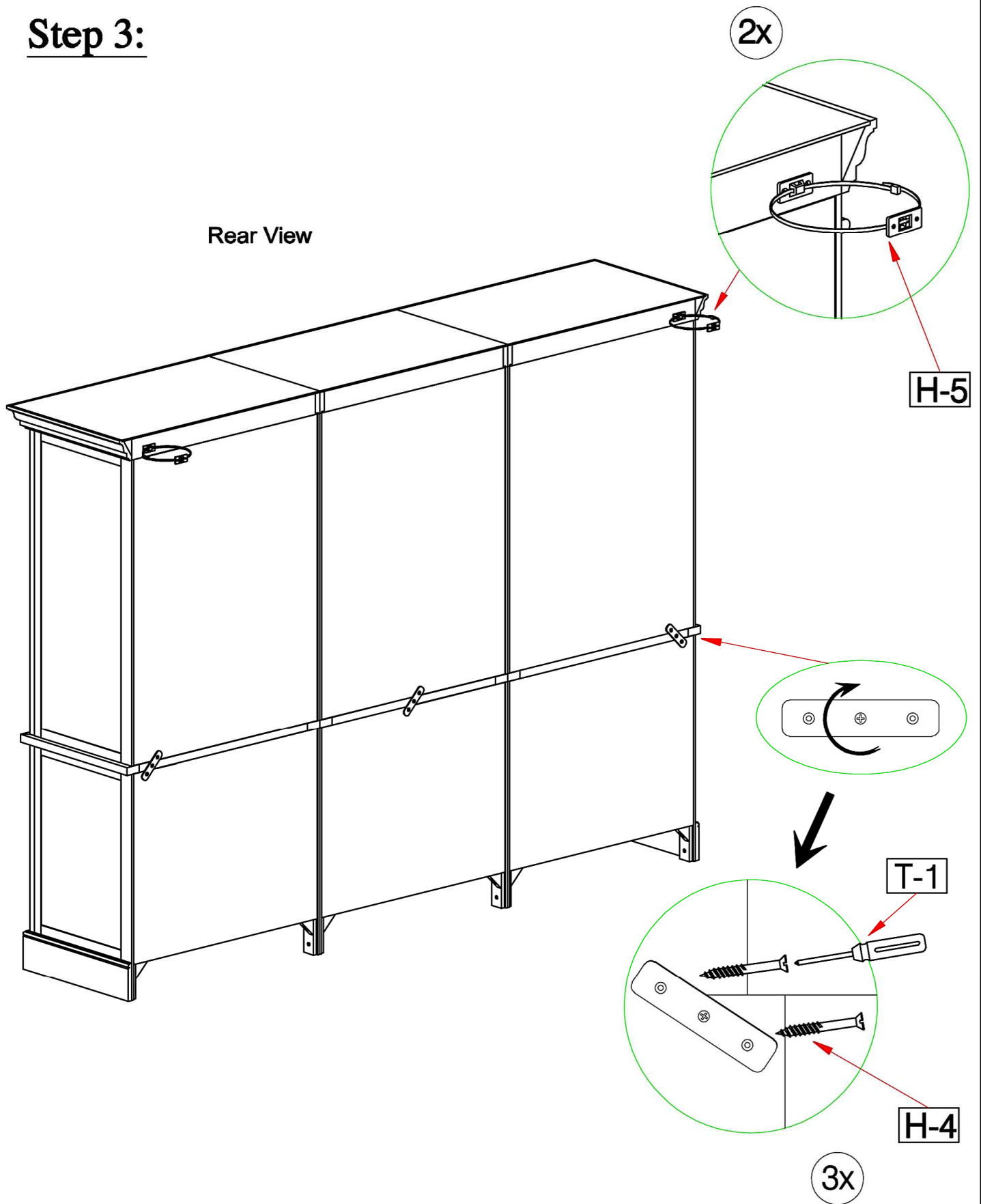

- Turn 3 Metal Plates-Inserted at Top Base of frame, secure its to Base and Hutch with Screws (H-4).
- Install Anti-Tip Kit (H-5) to the top back corner of the Hutch as well as 2 pcs to the wall. Install them with Screws and Plastic Strings.

Step 4:

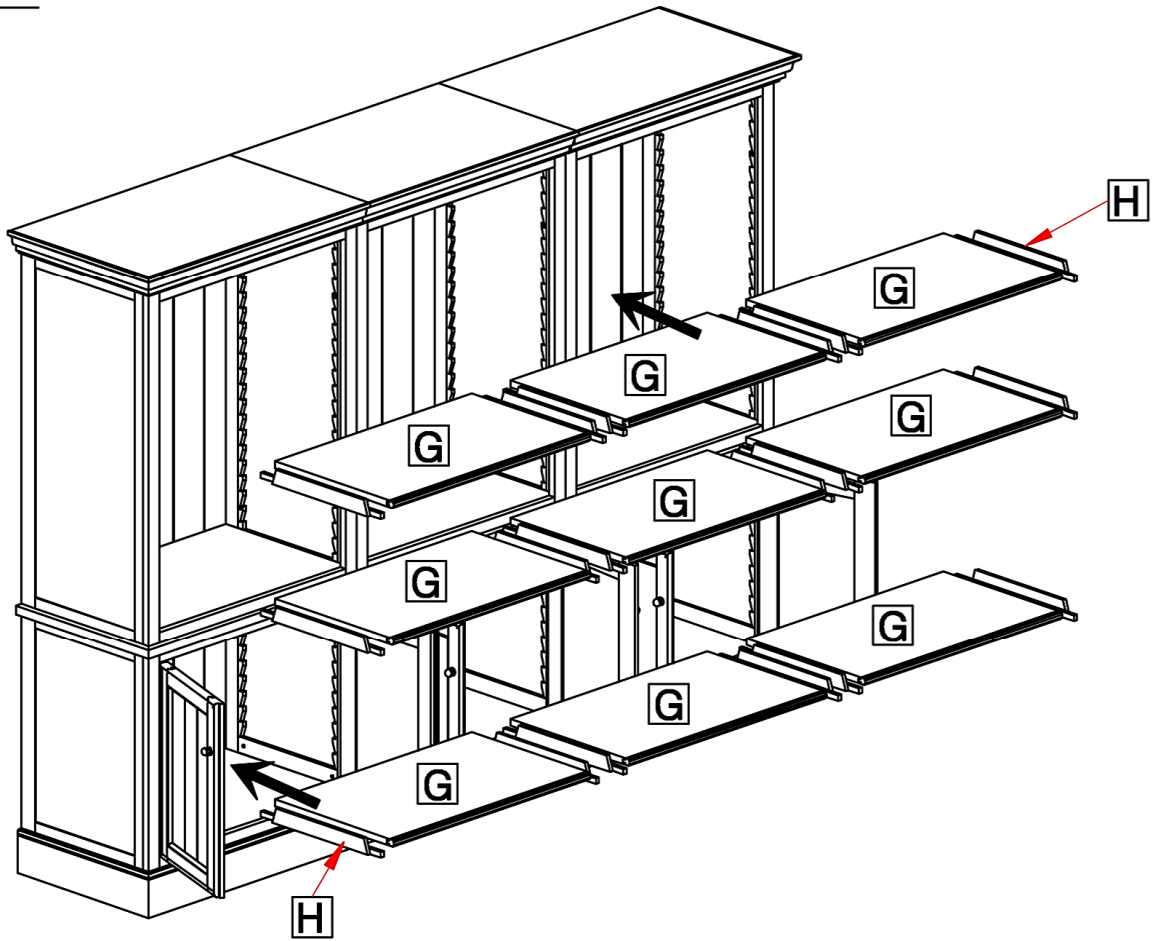

Place Shelves (G) into the Base and Hutch by Shelf Holders (H).

Step 5:

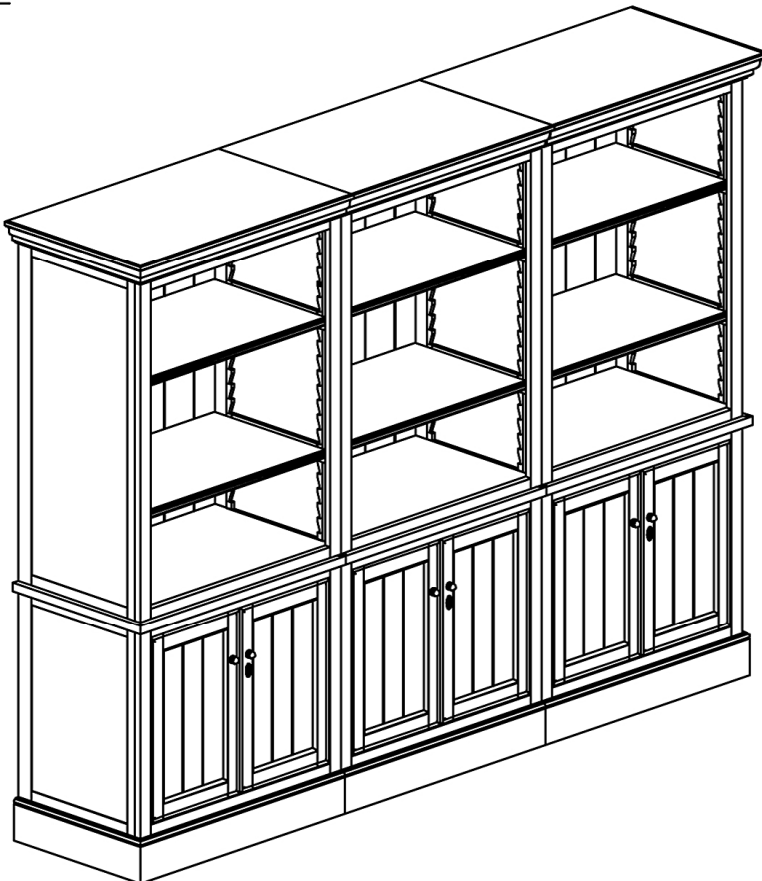

The Cabinet is assembled and ready for use.