

INDUSTRIAL STEEL PIPE TWIN BED





WARNING: ADULT ASSEMBLY ONLY OWING TO THE PRESENCE OF SMALL PARTS, SHARP POINTS AND EDGES.

CUSTOMER SERVICE: If you are missing parts or have any questions about this product, contact us at: 1-800-762-1751

PARTS LIST:

- | | |
|---------------|-------|
| 1. HEADBOARD | 1 PC |
| 2. FOOTBOARD | 1 PC |
| 3. SIDE RAILS | 2 PCS |
| 4. SLAT ROLL | 1 SET |

HARDWARE INCLUDED:

PART	DESCRIPTION			QTY
A		Bolt	1/4"x 2-1/2"	8 PCS
B		Bolt	1/4"x 1/2"	12 PCS
C		Nut	1/4"x 3/4"	12 PCS
D		Flat Washer	1/4"	8 PCS
E		Allen Wrench	1/4"	2 PCS

Assembly Instructions:

Note: ****2 people are recommended for assembly of this bed.**

****Do not completely tighten all bolts until all steps are finished.**

Step 1: Attach Side Rails (3) to Headboard (1) and Footboard (2) with Bolts (A) and Flat Washers (D).

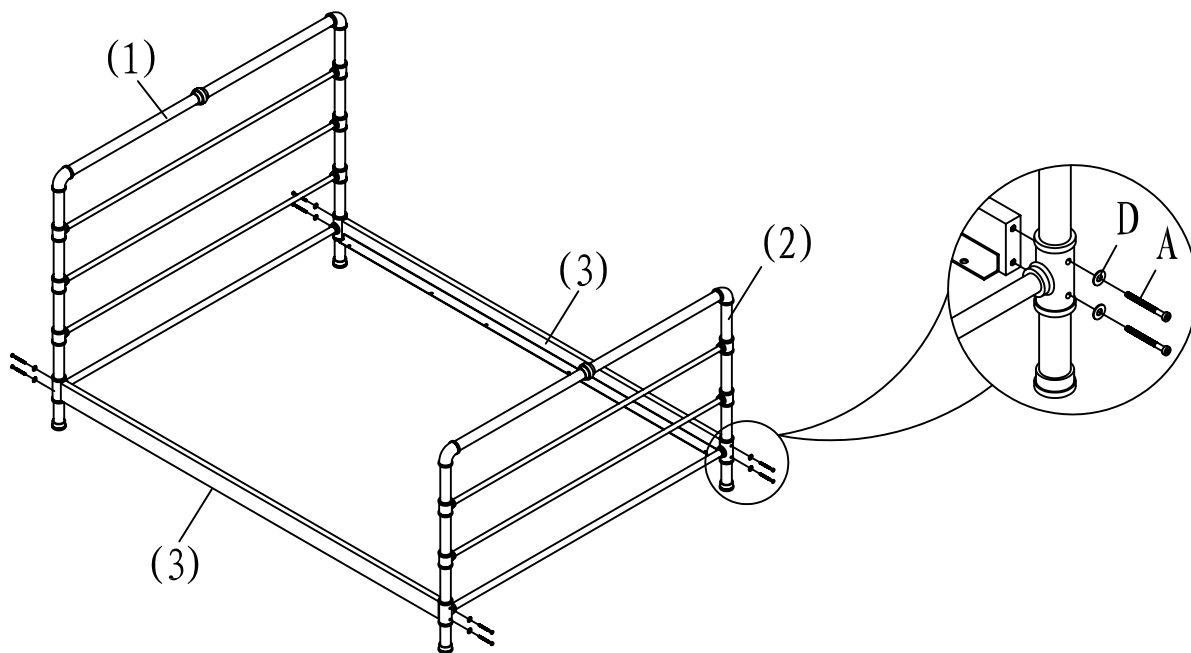

Step 2: Lay the Slat Roll (4) on bed in between the Side Rails (3). Then attach the Slat Roll (4) using Bolts (B) and Nuts (C) at illustrated locations. Completely tighten the Bolts (B) and Nuts (C) at 6 locations per side, for a total of 12 bolts per bed.

Remark:

1. Please note that to correctly assemble the slats, the webbing on the slats should be on the bottom side.

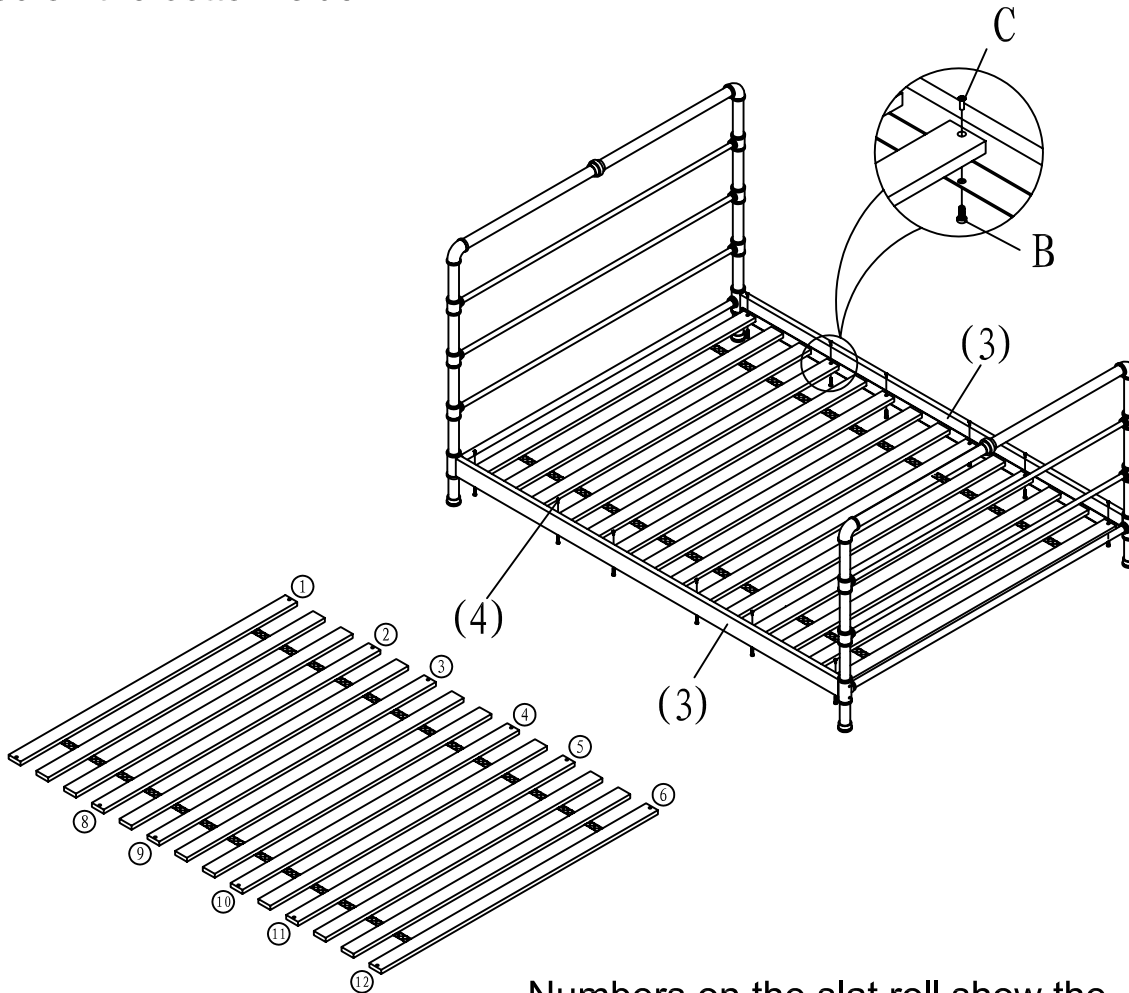

Numbers on the slat roll show the locations to tighten the bolts and nuts.

CARE INSTRUCTIONS

- Dust often using a clean, soft, dry lint-free cloth.
- Blot spills immediately, and wipe with a clean, damp cloth.
- We do not recommend the use of chemical cleansers, abrasives, or furniture polish on our lacquered finish.

Thank you for you purchase
www.rhbabyandchild.com