



PARTS

- A [1] SHELF
- B [2] BRACKETS (Included)

No.	ITEM	DESCRIPTON	QTY.
1		1.5" Screw	4 PCS
2		1" Screw	4 PCS
3		Anchor	4 PCS

ASSEMBLY INSTRUCTIONS

The following instructions are for use with the coordinating Industrial Plank Shelf (36" or 48") and drywall/stud-mounting only. Please consult local hardware store or professional for any other uses or installation types.

Professional installation recommended

1. Carefully unpack the contents of the carton.
2. Position the shelf on top of the brackets. The back of the shelf should be flush against the wall.
3. Place the shelf on a flat surface and measure the distance between the pre-drilled pilot holes on underside of the shelf. This distance will help determine spacing for the shelf's brackets on the wall.
4. Using a screwdriver (not included), affix the shelf to the brackets with 1" screws (2).
5. Mark the centers of the bracket holes onto the wall with a pencil.
6. Insert drywall anchors (3) into wall at marked places (gently tapping in until flush with wall). Place both brackets in position on the wall over the inserted anchors. Using a screwdriver, insert 1.5" screws, pressing firmly to prevent anchor from rotating. Tighten screws until resistance is felt; this will fully expand the anchor.
7. Assembly is complete.

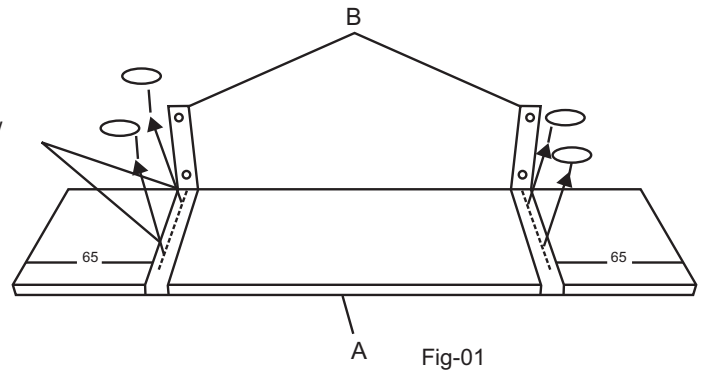
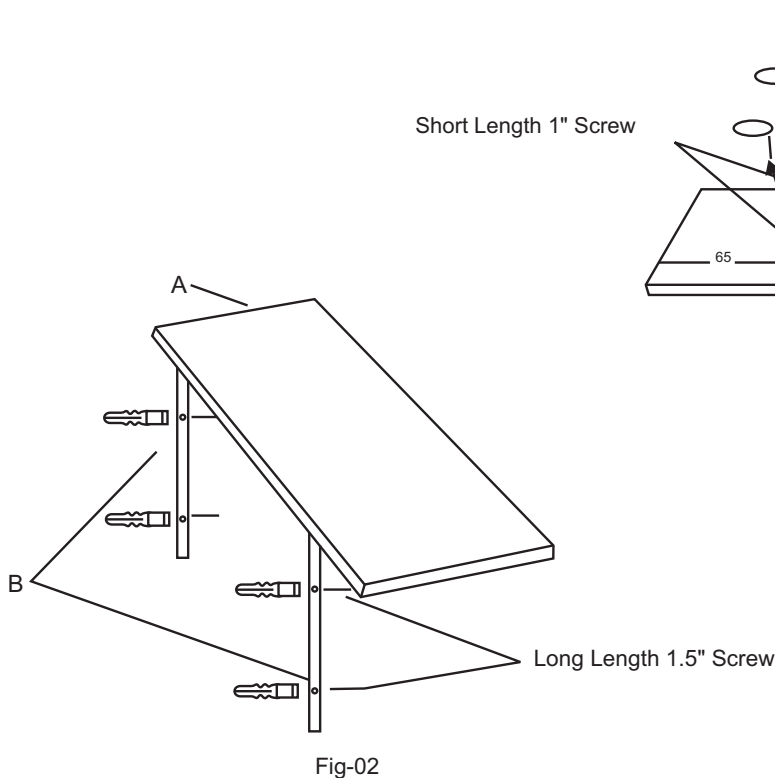

CARE INSTRUCTIONS

1. Clean periodically by wiping the shelf with a dry cloth.
2. Do not use abrasive cleaners, chemical cleaners or metal polishes.

IMPORTANT SAFETY INSTRUCTIONS

1. Professional installation recommended.
2. Do not place heavy objects on the shelf.
3. Never sit on, stand on or apply heavy pressure to the shelf.
4. When using our coordinating Industrial Plank Shelf (36" or 48"), recommended max loading weight is 36 lbs for 36" plank shelf and 48 lbs for 48" plank shelf.