

baby&child

RESTORATION HARDWARE

Thank you for selecting Restoration Hardware Baby & Child lighting. Our assortment is crafted with the highest quality materials that coordinate perfectly with our Baby & Child bedding collections, making it easy to create an elegant nursery or child's bedroom. The item's surface is sealed, which eliminates the need for polishing and ensures a lasting finish for years to come.

PARTS INCLUDED:

- A [1] MOUNTING PLATE
- B [2] PLASTIC WIRE CONNECTOR
- C [1] GROUND SCREW
- D [2] MOUNTING SCREW
- E [2] JUNCTION BOX MOUNTING SCREWS
- F [1] BACK PLATE
- G [2] NUTS
- H [2] SOCKET
- I [2] BULB [NOT INCLUDED]
- J [1] FLUSHMOUNT
- K [1] DIFFUSER
- L [1] FINIAL

IMPORTANT SAFETY INSTRUCTIONS:

WE RECOMMEND INSTALLATION BY A LICENSED ELECTRICIAN.
 This fixture has been rated for up to two (2) 40-watt maximum type B bulbs. To avoid the risk of fire, do not exceed the recommended wattage.

WARNINGS:

All wires are connected. When unpacking, be careful not to pull wires as a bad connection may result. Do not connect electricity until your fixture is fully assembled. To reduce the risk of fire, electrical shock, or personal injury, always turn off fixture and allow it to cool prior to replacing the light bulb. Do not touch bulb when lamp is turned on or look directly at lit bulb. Keep flammable materials away from lit bulb.

THIS IS NOT A TOY AND THE PRODUCT HAS NO PLAY VALUE

INDUSTRIAL BURLAP FLUSHMOUNT

TO ASSEMBLE:

1. Carefully remove all parts from the box and remove all plastic covering.
2. Turn OFF power to the junction box where the flushmount will be installed.
3. Connect the hot wire (black wire) to the hot junction box wire with a plastic wire connector (B) and wrap the connection with electrical tape. Connect the neutral wire (white wire) to the neutral junction box wire with a plastic wire connector (B) and wrap the connection with electrical tape.
4. Attach the ground wire (silver wire) from the fixture to the ground junction box wire in the outlet box, or wrap the ground wire around the ground screw (C).
5. Attach the mounting plate (A) to the outlet box using the mounting screws (E) and tighten.
6. Attach the back plate (F) to the mounting plate (A) using the mounting screws (D).
7. Insert (2) 40-watt max. bulbs (I) (not included) into the sockets (H).
8. Tighten the flushmount to the back plate (F) with the nut (G).
9. Tighten the diffuser (K) to the flushmount (J) with finial (L).
10. Restore power to the junction box and test fixture.
11. Installation is complete.

Direct Wire Installation

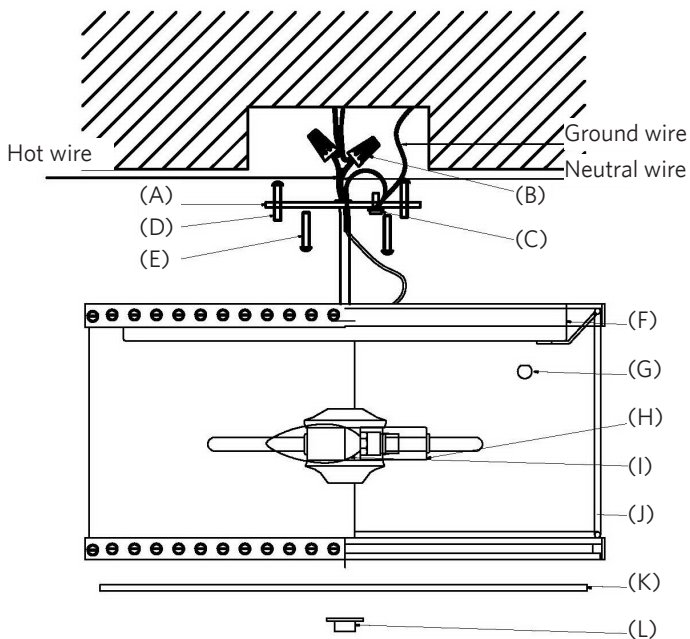

CARE INSTRUCTIONS:

Do not use polishes or cleaners on your fixture.
JUST WIPE CLEAN WITH A SOFT CLOTH.